



LAST UPDATED
July 2019

INSTALLATION MANUAL
Bali • Praga • Kronos • Iris • Ares • Miranda

MAIN SEAT COMPONENTS

PRE INSTALLATION RECOMMENDATION

Verify the following information before beginning the installation

1 COMPARE AND VERIFY

-Please compare the layout (previously approved) with physical space and verify conditions of the place.



(x8) Screw
M6* 35mm



(x2) Anchor Bolt
3/8* 1 7/8"

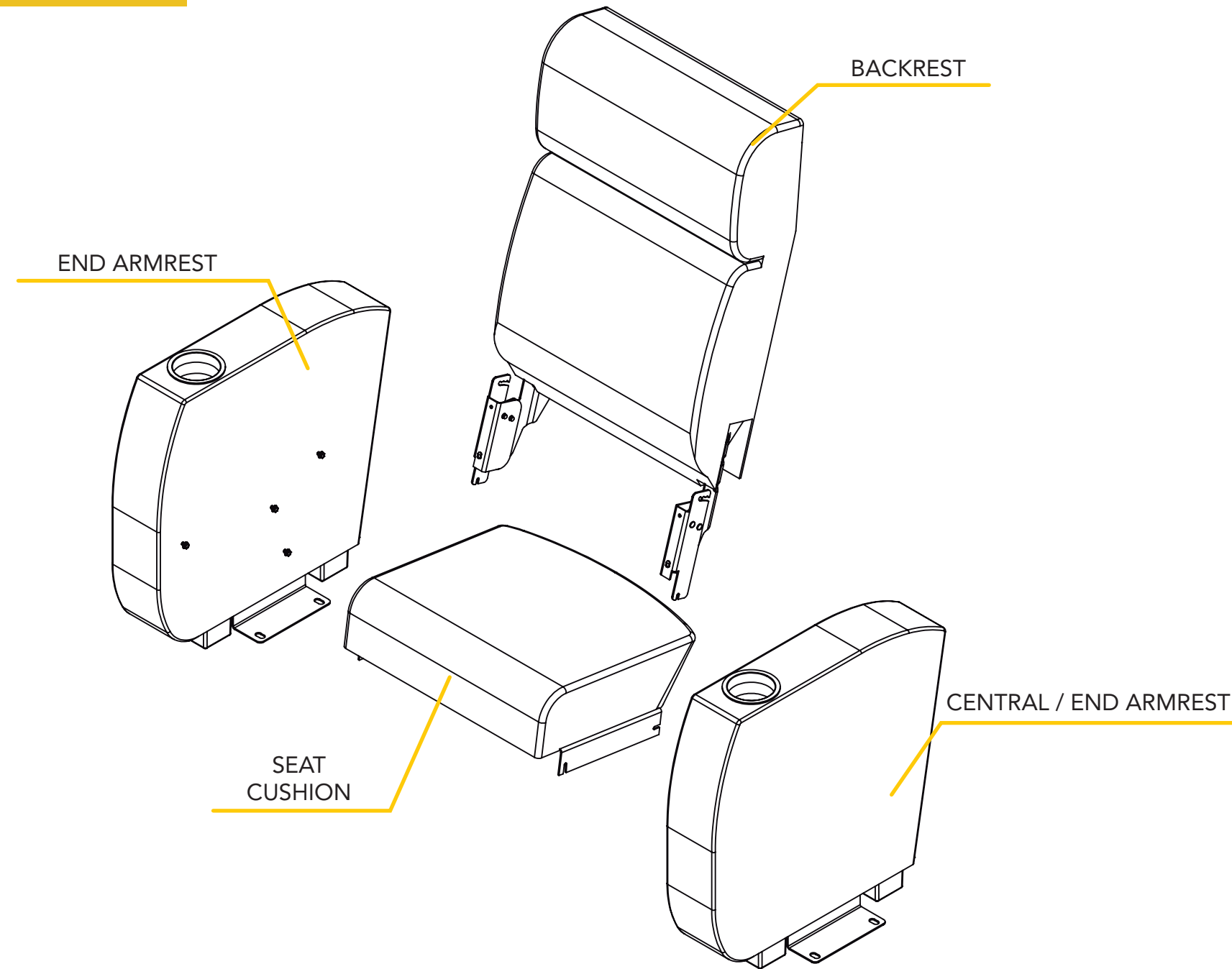

2 VERIFY THE REQUIRED TOOLS



Plastic ties



Drill bit
3/8-inch diameter



Pencil



Drill



Measuring tape

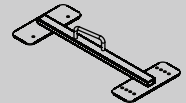

Drilling template



Hexagon
10mm and 1/2"
wrench

3 IDENTIFY THE MAIN PRIME SEAT COMPONENTS

-Central and end armrests are individually shipped and attached to seat with mounting bolts.

-Backrest and seat cushion are individually shipped.

TYPES OF INSTALLATION

CENTRAL / END ARMREST TYPES

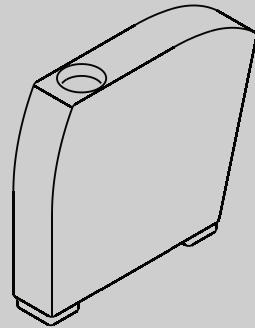

FIXED

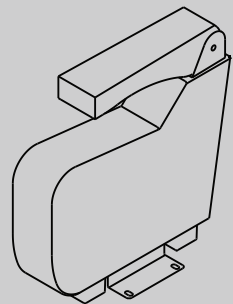

LOVESEAT ARMREST
ADA

DOUBLE TANDEM

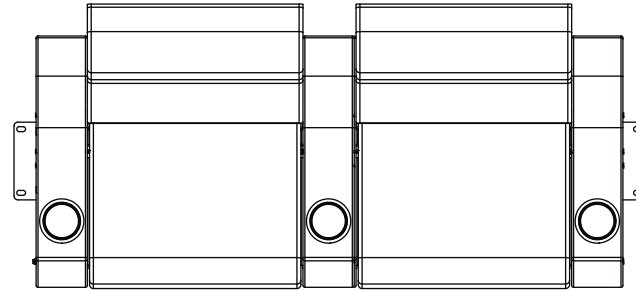

3 SEATS TANDEM

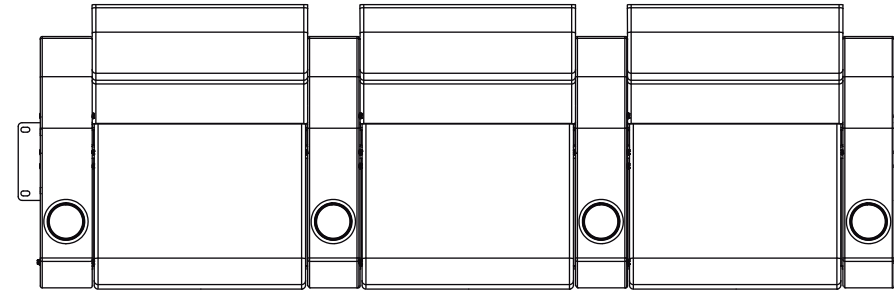

INDIVIDUALLY PLACED

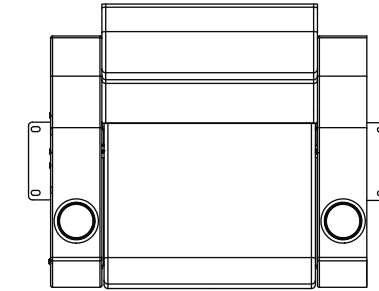

CONTINUOUS ROW

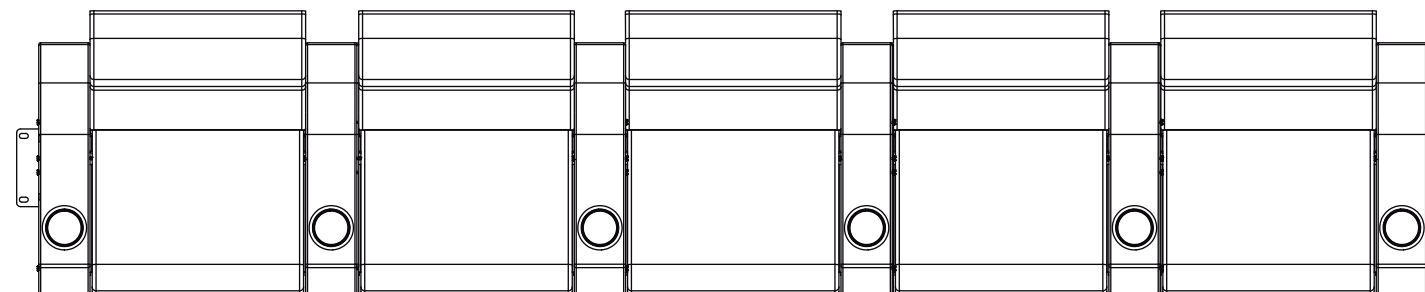

✓ Once configuration type is identified, place seats according approved layout

ANCHORING ARMRESTS TO FLOOR

NOTE

Concrete floors require a tungstene drill bit.

Use 5/16" x 1-1/2" self-drilling screws for wooden floors.
(No previous drilling is necessary)

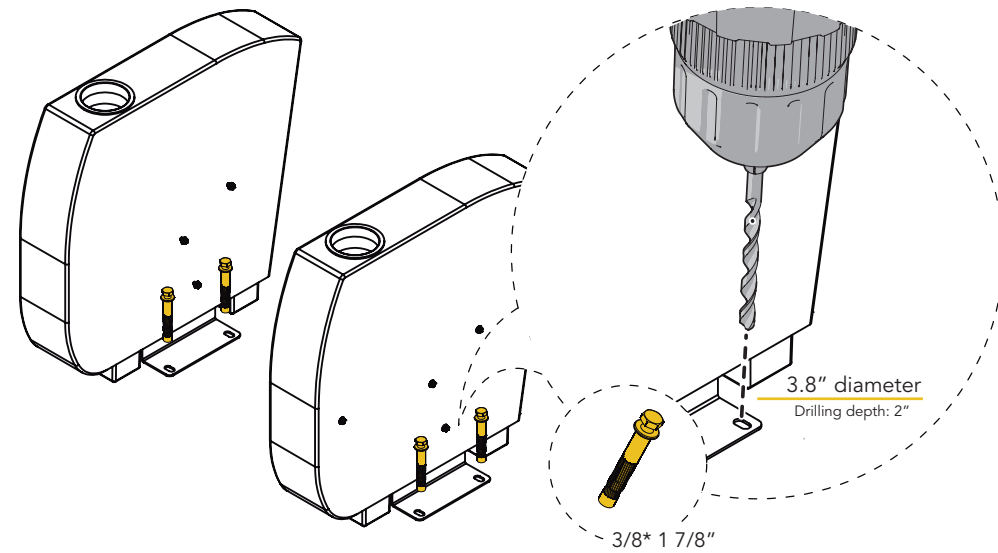
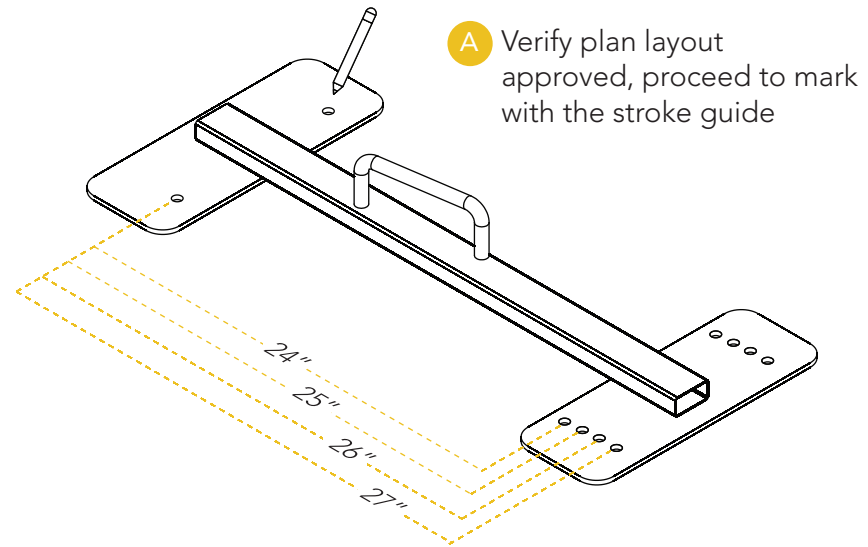

Drill holes on the floor, get the excess dust out and fix armrests using anchor bolts.

PLACE THE BACKREST

NOTE

Make sure back is correctly installed. It should be adjusted and should not be able to easily back and forth.

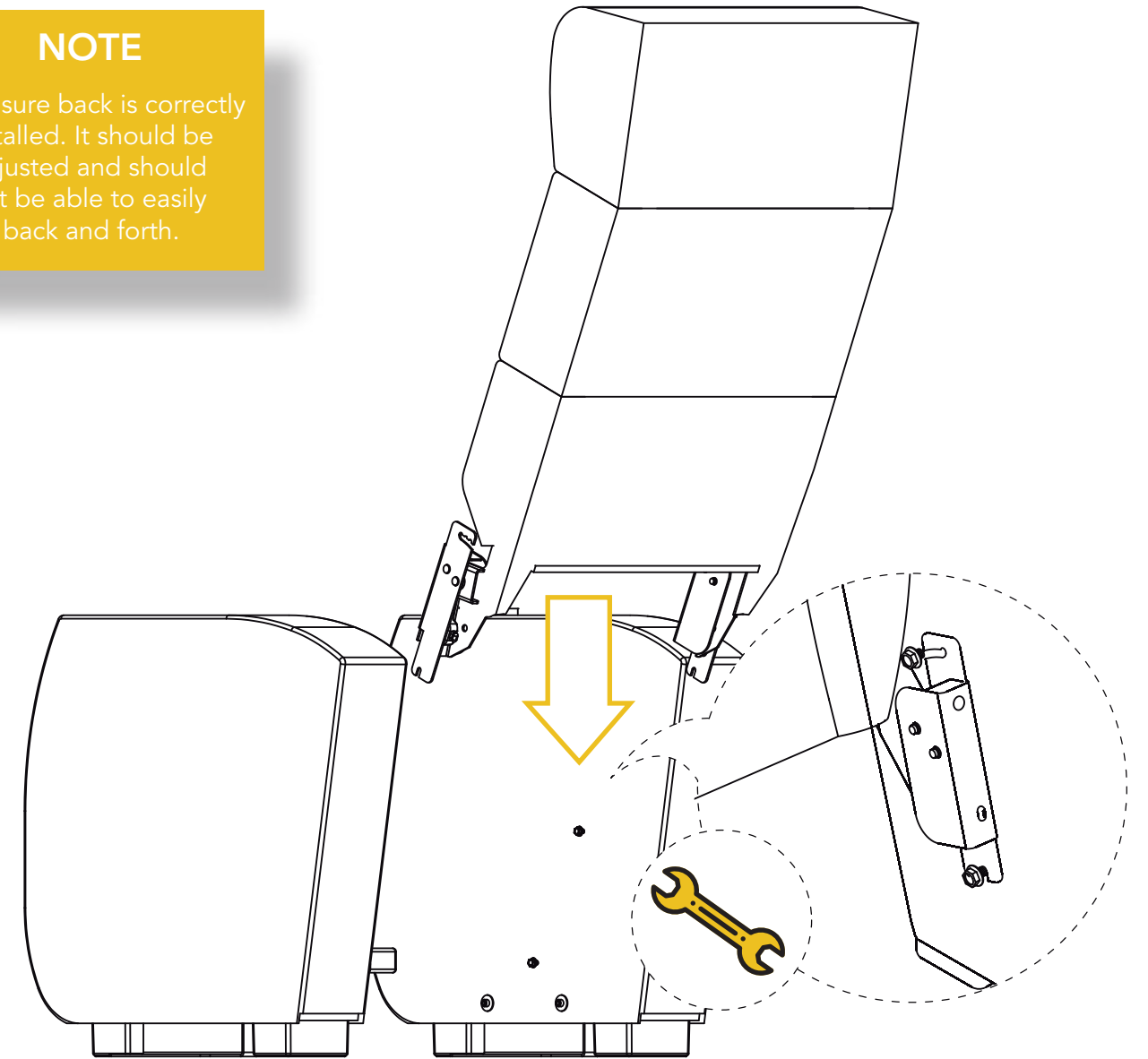

Locate the backrest so the plates perforations fit into the panel screws. Proceed to tighten the screws.

CUSHION ASSEMBLY

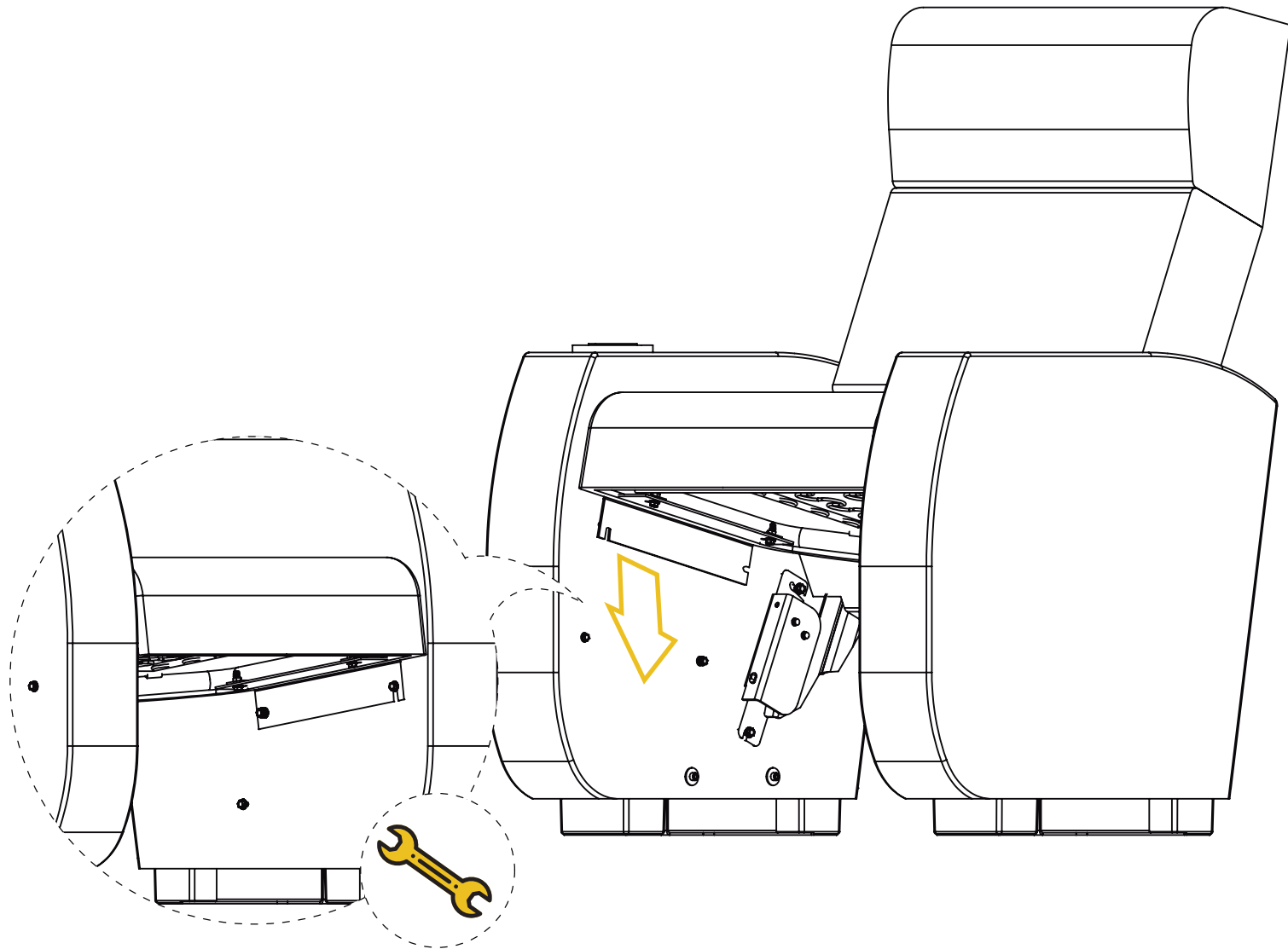

Locate the cushion between the panels. Holes in the plate should fit with the holes of the panel.
Insert screws and adjust

ACCESSORIES INSTALLATION

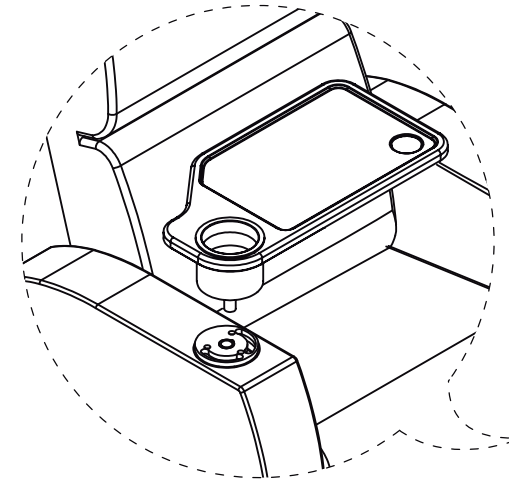

A SWIVEL TABLE

Insert table pin in the armrest surface hole. The table's position should be same as shown in the image. Both right and left hand sides can be used, depending on approved layout.

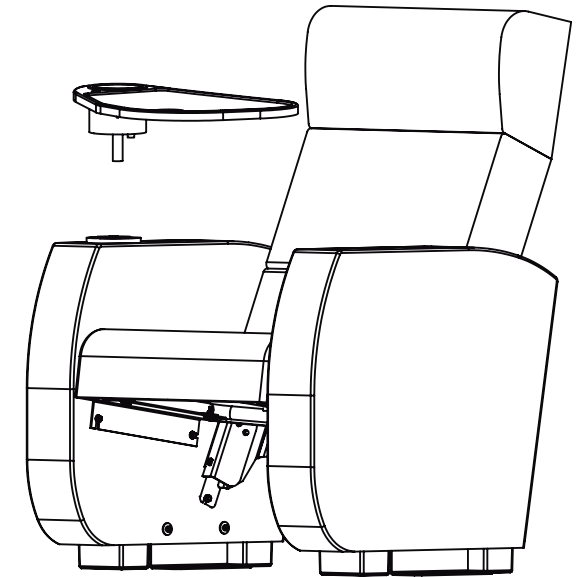

B REMOVABLE HEADREST COVER

Install cover with the numbering or logo facing the front (according to layout)
Make sure the lowest cover seam align with stitching on back headrest.

LIMITED WARRANTY

INORCA SAS warrants solely to the original purchaser that the product purchased is free of defects in material and workmanship. This warranty is effective for five (5) years from the date of purchase except as provided below. This warranty does not cover damage to the product or parts caused by abuse or neglect, inappropriate use, destruction by any casualty, including flood, electrical power surges or power failures, acts of God, fire, explosion, theft, or vandalism, or failure to properly install or maintain the product or its parts. Attempted repairs by third parties shall void this warranty. INORCA SAS's liability is limited to replacement of the warranted parts in accordance with this limited warranty, or, at the option of INORCA SAS, the entire product. Replacement of the product or any part thereof shall not extend the original warranty period. INORCA SAS will assume the cost of labor and shipping and handling to repair or replace defective part(s) covered under the warranty for one (1) year from the date of original purchase and thereafter such expenses will be borne by the purchaser. INORCA SAS shall not be responsible for loss of time, lost profits, injury to person or property, or other incidental, consequential, punitive, exemplary or other damages or costs incurred by any party. **The terms and limitations of this paragraph apply to all material or component warranties below and the warranty contained in this paragraph is further limited as to any part or portion of the product as provided below. This warranty applies to all sales made by INORCA to the Purchaser.**

INORCA SAS SHALL HAVE NO RESPONSIBILITY UNDER THIS LIMITED WARRANTY IF PURCHASER IS DELINQUENT IN ANY PAYMENT DUE TO INORCA SAS FOR THE PURCHASE OF THE PRODUCTS.

EXCLUSIONS

The guarantee, if any, for fabrics, leathers and faux leathers (upholstery materials), wood solids, veneers, and laminates used in conjunction with the product is limited to the component manufacturer's guarantee/warranty. In no event will the warranty period for leather exceed one (1) year from the date of purchase. INORCA SAS will not be responsible for misuse, wear and tear or abuse, or changes in finish, color, shading or surface texture due to aging, job site conditions, or the natural character of wood solids, veneers and laminates.

The limited warranty period hereunder for any upholstery material is limited to repair or replacement of such parts or portions that suffer from manufacturing or material defects. No two pieces of leather are alike, and as such, natural markings and grain variations shall not constitute defects and are not covered under this limited warranty.

The fabric, faux leather and leather warranty is void where there is evidence of excessive soiling, improper cleaning, abuse or where the upholstery materials had a chemical treatment applied by the retail dealer, consumer, or any other party.

LIMITED WARRANTY

ELECTRIC MECHANISMS AND ELECTRONIC DEVICES

The warranty, if any, of electric or electronic mechanisms or devices incorporated into INORCA's products is limited to the warranty provided by the manufacturer of said components.

CUSHIONING AND INNER STRUCTURE

Cushioning and inner structure are warranted against defective material or workmanship for the full five (5) years from the date of original purchase of the product initially provided above. However, all foams and filling composites naturally soften with use. This softening does not constitute a defect and is not covered under this limited warranty.

Leggett & Platt scissor mechanisms used in INORCA recliners are limited to the warranty provided by the manufacturer of said components.

TABLES, ACCESSORIES AND ALL OTHER PARTS

All other parts not specifically warranted, including but not limited to tables, cupholders, tabletops and number or letter plates, have a one (1) year limited warranty against defective material or workmanship. This warranty is limited to repair or replacement of the defective part.

WARRANTY LIMITATIONS

THE LIMITED WARRANTIES DESCRIBED ABOVE ARE THE EXCLUSIVE WARRANTIES IN RESPECT OF THE PRODUCT AND ANY PART OR PORTION THEREOF AND SHALL BE IN LIEU OF ANY OTHER WARRANTY, EXPRESS OR IMPLIED, INCLUDING BUT NOT LIMITED TO ANY IMPLIED WARRANTY OF MERCHANTABILITY OR FITNESS FOR A PARTICULAR PURPOSE. IN NO EVENT SHALL THE AGGREGATE LIABILITY TO OR THROUGH PURCHASER AND IN RESPECT OF ANY PRODUCT EXCEED THE AMOUNT PAID BY THE PURCHASER FOR SUCH PRODUCT.

The parties agree that INORCA SAS's sole liability shall be for the repair, or at INORCA SAS's discretion, replacement of the defective part as provided herein, subject to the limitations in respect of any such repair or replacement as provided herein, including limitations on costs or expenses thereof. INORCA SAS will not be responsible for shipping or installation costs for warranty claims occurring one (1) year after the original purchase. INORCA SAS will never be responsible for any loss of time, lost profits, injury to person or property, or other incidental,

LIMITED WARRANTY

consequential, punitive, exemplary or other damages or costs incurred.

Note: in jurisdictions that prohibit limitations on the duration of an implied warranty or the exclusion or limitation of any particular form or type of damages, the affected above limitations shall not apply except to the extent the limitations are permitted under such jurisdictions.

REQUIRED FLOOR SPECIFICATIONS AND MAINTENANCE

Purchaser is responsible for regular maintenance and inspection of the product. "Regular maintenance" shall include tightening of any loose assembly and attachment hardware, replacement of damaged components, and proper cleaning (including removal of dirt on the powder coated steel, especially on attachment footplate). This work shall be performed at reasonable intervals based on frequency of use, but at least every six (6) months. Regular inspection of product components, including assembly hardware, moving parts, and anchoring devices is also part of required maintenance. Strenuous use requires weekly inspection. All hazards are required to be corrected prior to use. Purchaser is also responsible for ensuring the product is properly installed according to the specifications provided by INORCA SAS or the product or part manufacturer and under applicable building and similar codes and regulations, including those provided below. Failure to conduct "regular maintenance" or to comply with such specifications, including those below, shall void this limited warranty.

Concrete Floor:

For fixed-backrest chair installation, the floor on which the seating is to be installed must be concrete with a strength of at least 3,000 PSI and a minimum thickness of 10 cm. Each chair must be installed to the floor with two (2) expansion anchor bolts delivered and specified by INORCA SAS and installed diagonally on the fixing floor plate of each standard.

For reclining backrest chair installation, the floor on which the seating is to be installed must be concrete with a strength of at least 3,000 PSI and a minimum thickness of 10 cm. Each chair must be installed to the floor with three (3) expansion anchor bolts delivered and specified by INORCA SAS and installed on the fixing floor plate of each standard.

Wood Floor:

For fixed-backrest chair and reclining backrest chair installation in a wood floor, the floor must be a hardwood floor, with a minimum thickness of one inch (1"). Each chair must be installed to the floor with four (4) self-tapping screws supplied and specified by INORCA SAS, one in each hole of the fixing plate.

LIMITED WARRANTY

The foregoing minimum standards may be revised from time to time by INORCA SAS upon notice to the purchaser, including subsequent to installation.

MEDIATION REQUIRED

Purchaser hereby agrees and consents to a mandatory mediation prior to bringing any lawsuit, administrative claim, or other demand to adjudicate a claim. Mediation shall be before the American Arbitration Association and shall take place in or near the location of Purchaser's place of business where the INORCA SAS products at issue are in use or to be installed. While this mediation is mandatory, it is not arbitration and will be an attempt at resolving claims by agreement using an unbiased third party who is a member of the American Arbitration Association's construction division for arbitration of claims. The parties will each bear 50% of the cost of the mediator, and shall otherwise bear their own attorneys' fees and costs for the mediation. The mediator shall be selected by mutual agreement, or if no agreement can be reached between the parties, the mediator shall be appointed by the American Arbitration Association.

This agreement shall be construed and controlled by the laws of the State of Texas and Purchaser consents to exclusive jurisdiction and venue in the federal and state courts located in or nearest to Collin County, Texas. Purchaser waives all defenses of lack of personal jurisdiction and forum non conveniens.

ENTIRE AGREEMENT

INORCA SAS's entire warranty and liability in respect of the product is embodied in this writing, irrespective of any statements, written or oral, made by any employees or agents of INORCA SAS. Any such statements do not constitute warranties or create liabilities, and shall not be relied upon by purchaser, and are not part of this warranty. This writing is a complete and exclusive statement of the terms of INORCA SAS's warranty and may not be modified, altered, or amended except in a writing signed by an authorized officer of INORCA SAS.

MAINTENANCE AND CLEANING MANUAL

It is important that the highlighted instruction and procedures in this guide are carefully read. In case of any defects or doubts, please contact us.

TEXTILES (This should be applied for polypropylene, polyester, or polyvinyl fibers).

- Periodical cleaning is recommended to maintain the best appearance of the upholstery.
- Use a mild soapy solution, removing completely when done. Always use a damp white cloth.
- Remember that lighter colors, such as whites, require more frequent cleaning.
- The following products can cause permanent damage to the material: thinners, acetone, alcohol, bleaches, waxes, silicones or detergents.
- Avoid using ink pens or markers as they can penetrate into the product, causing a permanent stain.

RECOMMENDATIONS

- Avoid continual exposure to the sunlight as this could reduce the quality of the textile or the skin and degrade its color and tonality.
- Dry in a shady location.
- It is highly recommended to not use plastic sponges, wire, brushes or pulverisers designed for industrial or household use.
- The use of foamy products on or under the upholstery is not recommended.
- Avoid sitting on the chair with sharp objects in your possession, such as scissors or keys. They can damage the tissue fabric of the upholstery, causing cuts, rips and or defects.

WOOD (applicable for veneer finishes)

- Clean with water and soft soap that does not contain abrasive agents, using a clean, white, damp rag, that will not leave dust particles or specks.
- Do not clean with solvents like thinner, mineral spirits, acetone, alcohol, bleaches, waxes, silicones, or detergents. These can cause permanent damage.
- To remove stains or persistent dirt, wipe with a damp rag soaked with a soft cleaning product (or a sodium bicarbonate diluted in water) on the entire wood surface, and wipe in the direction of the grain.
- After eliminating the stains and cleaning up all the residue, dry the surface completely in order to have a uniform appearance.

MAINTENANCE AND CLEANING MANUAL

RECOMMENDATIONS

- Do not use the surfaces for chopping or cutting.
- Regularly clean off dust to avoid accumulation.
- Do not place anything hot directly on the surface.
- The wood and plastic surfaces are sensitive and are easily scratched or scraped, cut and punctured if they have direct contact with abrasive, cornered, or sharp objects.

POWDER COATING FINISH

- It is recommended to clean traces of grease, stains, sweat, salt, liquids, dust or general contaminants with a soft cloth and mild water soap solution that does not scratch the surface of the product. Allow to dry completely.
- In the event of cleaning more stubborn areas, a neutral industrial soap can be used to replace the mild soap.
- When cleaning a structure or section that has an electrostatic paint finish, be sure to completely dry the affected area, as leaving moisture on the surface of the paint can deteriorate the finish and produce oxidation.
- Avoid sitting on the chair with sharp objects in your possession, as they can scratch the paint on the structure. Chair maintenance should be performed periodically ensuring proper operation.
- Quarterly checks are recommended for any necessary adjustments to the hardware.

The use of substances such as hypochlorite, solvents, acidic products, even alcohols will lead to the loss of gloss, change of finish, surface scratching and or chemical deterioration.

RECOMMENDATIONS

- Best cleaning methods suggest following the grain of the metal and never against it, as scratching may occur. Wipe with a clean dry cloth when done.
- The use of powder detergent to clean surfaces is not suggested, since the microparticles of the active agent can cause scratching.
- Whenever cleaning your product, dry completely with a clean, dry cloth.
- The use of abrasive tools such as brushes and wire sponges can penetrate the protective steel film, giving a negative appearance of corrosion and rust.

MAINTENANCE AND CLEANING MANUAL

PLASTIC PIECES

- Clean plastic pieces with warm soapy water or neutral Ph. softener and a soft white damp cloth and dry completely.
- Avoid use of pens and markers to avoid permanent stains.
- Do not use solvents such as thinners, mineral solvents, acetone, alcohol, bleaches, waxes, silicones, or detergents.
- Avoid sitting with any sharp instruments that can scratch, scrape or cut the seat.
Soft brush made of pig hair is recommended to clean porous plastic pieces to remove deep stains and or spots.
- Do not use rags or cloth that have been previously used on other material
- For difficult or stubborn stains, use BIODEGRADABLE POWERED OXIGENATED BLEACH or SODIUM PEROXICARBONATE (DILUTED IN WATER – 20 grams per liter of water)

RECOMMENDATIONS

- Avoid long term exposure to sunlight as it can damage color and diminish quality of textiles or leather.
- Allow to dry in a shaded area.
- Do not, under any circumstance use plastic or wire scrub pads brushes, polishers or disk buffers.
- Do not allow the foam cushion inside the upholstery seat to get wet
- Keep sharp objects away from seats such as scissors, keys as these elements can damage upholstery materials
- Clean plastic pieces with warm soapy water or neutral Ph. softener and a soft white damp cloth and dry completely.
- Avoid use of pens and markers to avoid permanent stains.
- Do not use solvents such as thinners, mineral solvents, acetone, alcohol, bleaches, waxes, silicones, or detergents.
- It is important to dispose of unused cleaning solvent and any unused surplus as well as cleaning cloths. Use fresh / clean cloths and solvents each time.
- Soft brush made of pig hair is recommended to clean porous plastic pieces to remove deep stains and or spots.
- Do not re-use cleaning rags /cloths