

NOVA

auditorium seating



TECHNICAL SPECIFICATIONS

PRODUCT DESCRIPTION

NOVA with tablet arm version provides the same construction and materials as standard NOVA but with a useful tablet arm, available in medium and large sizes. The NOVA model blends robustness, ergonomics, and sophistication, also with generous padding volumes of injected polyurethane foam to provide a kind sensation of comfort and satisfaction.

PRODUCT BENEFITS

- Replaceable back and seat covers, no staples or glue needed
- Assembly does not require specialized labor or tools
- Wide range of upholstery options, according to customer request.
- The shared centers provide a better use of space
- Complete range of sizes: Widths from 21" to 23" (533 to 584 mm) / Heights: 35" and 38" (890 and 965mm)
- Lineal, radial (26 ft / 8m minimum), or sloped installations are available for wood and concrete floor
- Serpentine springs add comfort, support and longer life to the seat bottom.
- Can add 15%-20% more patrons in same space, as quiet gravity lift seats fold up to a smaller envelope, enabling more rows.
- Metal exposed components are electrostatic powder-coat painted in black, which provides them high durability and resistance against hits, scratches, humidity, chemical components, etc.

GENERAL CONDITIONS

Compliance

NOVA seating is designed and manufactured in compliance with the following performance criteria:

- SEATING DURABILITY TEST - STATIC: There shall be no sudden and major change in the structural integrity of the product after applying a load of up to 330 lb for one minute.
- SEATING DURABILITY TEST – CYCLIC: There shall be no loss of serviceability to the chair after completion an impact test of 100.000 cycles with a 125 lb bag weight
- ARM STRENGTH TEST – VERTICAL – STATIC: There shall be no loss of serviceability after applying a load of up to 150 Kg for one minute.
- ARM STRENGTH TEST – HORIZONTAL – STATIC: A 220 lb proof load applied once shall cause no sudden and major change in the structural integrity of the unit.
- ARM DURABILITY TEST – CYCLIC: Structural breakage or loss of serviceability shall constitute failure after completion an impact test of 100.000 cycles with a 220 lb bag weight.
- TABLET ARM STRENGTH TEST: There shall be no loss of serviceability after loading 130 lb

Scope

Seating will be installed on the floor by a set of vertical supports (with shared centers). The fixed back accommodates three pitch positions at 15°, 18°, and 21°. The seat cushion is counterbalanced with a gravity lift to ensure an automatic return to vertical position when the seat is unoccupied.

TECHNICAL SPECIFICATIONS

MATERIALS

Sizes

Sightlines will be accommodated as indicated on the seating plans. Seating with left- or right-hand tablet arms will be manufactured to accommodate 21", 22", and 23" (533, 558 and 584 mm) seat-center spacings. This seating model is available in 35" and 38" (890 and 965mm) height.

Back cushion assembly

High grade steel, one piece seat frame (18 gauge and 3/4" / 19mm diameter) for structural integrity. Cold molded polyurethane foam increasing from 2.7" to 4" (70 a 100mm) of thickness. Foam density is 2.18 lb per cubic foot. The upholstery fabric will be bonded to foam and structure through non-automated upholstery methods. The back assembly is joined to the uprights by 14-gauge cold-rolled steel plates. Back covers could be fully upholstered, plastic, or wooden type.

Plastic back: Injected high-impact polypropylene back shroud wraps around the edge of the inner structure board and the foam. Embossed for strength.

Wooden back: An optional wood back panel is 1/2" (12mm) thick, constructed by 3 plywood layers. The back panel will attach to the inner structure and foam with 4 plates of 11-gauge steel sheet. It could be painted or covered with High-Pressure Laminate (edges will be painted in black).

Note: Plywood may have variations in pattern, grain, and coloring that can produce inconsistencies in the finished product when it has been painted. These variations are normal and cannot be avoided.

Seat cushion assembly

The seat assembly is constructed in High-grade cold-rolled steel, one-piece seat frame (16 gauge and 7/8" / 22m diameter) for structural integrity. Cold cured molded polyurethane foam with an average thickness of 3" - 4" (76 - 100mm). Foam density is 2.18 lb per cubic foot. The upholstery fabric will be bonded to foam and structure through non-automated upholstery methods. 10 gauge serpentine springs for a better seat cushion support. Bottom cover could be fully upholstered, plastic, or wooden type.

Plastic outer-back: A textured seat shroud made of high-impact polypropylene or an optional acoustical seat shroud (with drillings).

Wooden outer-back: An optional wood back panel is 1/2" (12mm) thick, constructed by 3 plywood layers that could be painted or covered with High-Pressure Laminate (edges will be painted in black).

Flammability rating

NOVA seat is manufactured to meet California TB 117-2013 flammability testing requirements in its foam, fabrics, and vinyl. Some of our fabric and vinyl options meet Crib 5 testing.

Gravity lift mechanism

Seat pivot is an integral part of the seat assembly, it works by a counterbalanced mechanism that is maintenance-free and noiseless. Pivot includes an axle of 1/2" (12mm) diameter AISI 1020 steel, with a stamped 8-gauge steel sheet internal pivot stop. Seat pivots bushings are made in Nylon 6.6, and are attached to the seat by steel screws.

TECHNICAL SPECIFICATIONS

MATERIALS

Uprights

Floor mounted uprights are constructed of 16 gauge steel 1" x 2" (25 x 50mm) rectangular, seamless construction, welded to an anchoring floor plate made out of a stamped 11 gauge steel sheet by a robotic MIG welding, 4 hole foot for obstruction flexibility during installations. Powder-coat painted finish.

Armcaps

Armcaps are mounted on 11 gauge steel support, welded to the upright.

Thermolaminated: Machined in a medium-density fibreboard, constructed with a durable and decorative surface (PVC foil: Thickness: + 0.5 - 0.3mm) on the face and edges. Attached to the armcap support with bristol screws.

Laminated: Constructed by one plywood layer, covered with High-Pressure Laminate.

Tablet arm

The tablet arm is a storable writing surface constructed of a 9/16" (14 mm) plywood core, laminated on the face, and plastic profiles covering the edges. 116.2 in² (754 mm²) area for the standard version, and 139.7 in² (910 mm²) for the XL. Both are able to load 130 lb maximum.

Mechanism is made out of steel and allows store the table beside the uprights, at a slight angle, without interfering.

Aisle light (optional)

12V AC/DC Guide lighting fixture uses highbrightness LEDs to provide glare-free, nonintrusive illumination of aisles and steps. LED colors: Yellow, White and Warm White are standard, Red and Blue available. Optional row indicator with improved wider view window (150% larger than original) with edge lit illumination and etched alphanumeric display

LED Aisle light	
Light size	2.25" diameter
Voltage	12 V AC or DC
LEDs per fixture	9
Power per aisle	0.72W (1.3W with optional Row Indicator)
LED Color temperature	2500°k to 3100°k for warm white and 5000° to 6000°K for white
Operating fixture life	Yellow LED – 100,000-hour. White, Warm White LED – 50,000-hour
Lumens per fixture	29,56
Wire	Integrated wireway and end cap system available. 8" length

*Transformers are provided.

TECHNICAL SPECIFICATIONS

MATERIALS

Decorative end panels

Constructed from 20 gauge steel sheet, upholstered or laminated and fitted to the uprights.

Seat numbers (optional)

Optional white seat numbers are stamped on black polypropylene pieces, and are available for assembly into elliptical-shaped recesses on the front of the plastic seat shrouds, by self-tapping screws.

Row markers for end panels (optional)

Row markers are stamped on PMMA 2.3" (60mm) diameter pieces are available for assembly into end panels by self tapping screws.

Designated Aisle Seat - ADA Arm

Armcap support has a mechanism that makes it able to flip up and provides easy access for limited mobility occupants.

AVAILABLE CONFIGURATIONS

Height 35"	Height 38"	Height 40"	Width 19" a 23"	Width 21" a 23"	Upright in T shape	Upright in Z shape	Writing surface	HPL-metal end panel	Fabric-Metal end panel	Upholstered end panel	Laminated end panel	Wooden end panel	Thermolaminated end panel	Wooden armcap	Laminated armcap	Plastic armcap	Cupholder	Thermolaminated armcap	ADA armcap	Upholstered covers	Plastic / acoustic covers	Wooden covers	Laminated Covers	Thermolaminated covers
•	•		•	•		•	•	•						•			•	•	•	•	•	•		

FLOOR REQUIREMENTS

Concrete floor:

- Concrete with a strength of at least 3,000 PSI
- A minimum thickness of 4" (100mm).
- Each chair must be installed on the floor with two (2) expansion anchor bolts delivered and specified by INORCA SAS
- Must be installed diagonally on the fixing floor plate of each standard.

Wood floor:

- The floor must be hardwood
- A minimum thickness of 1" (25mm)
- Each chair must be installed on the floor with four (4) self-tapping screws supplied and specified by INORCA SAS, one in each hole of the fixing plate

FINISH GUIDE



DIMENSIONS (INCHES AND MILLIMETERS)

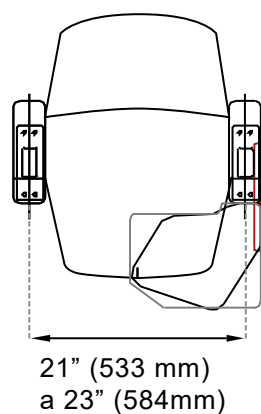
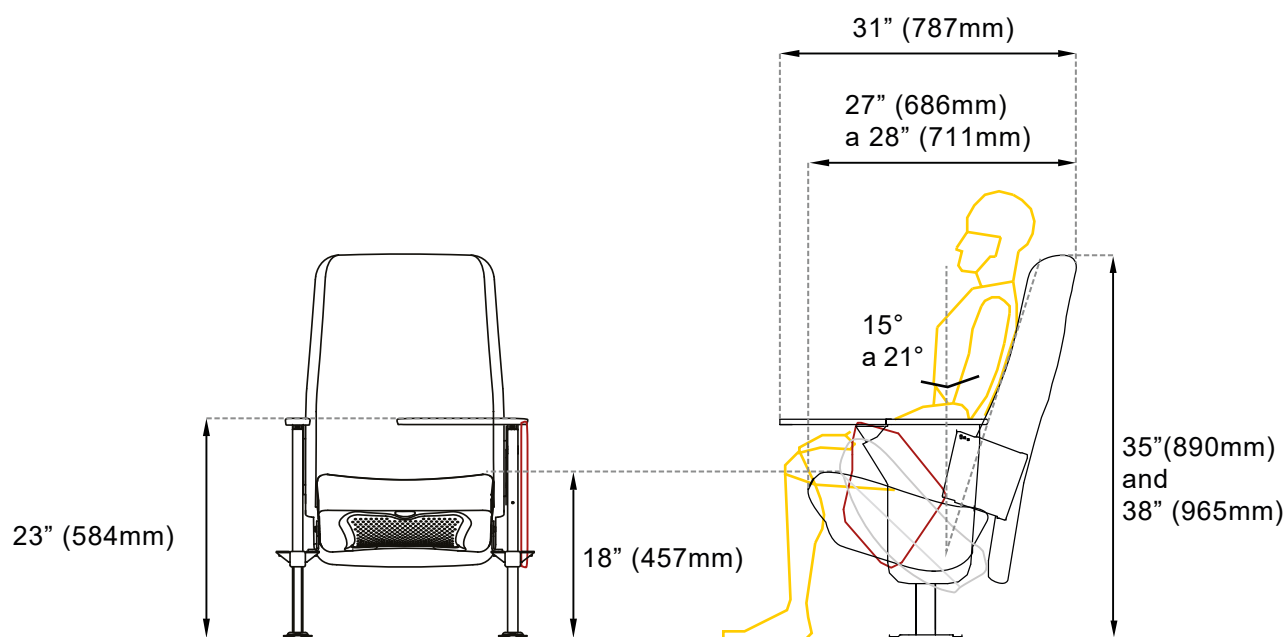

TABLET ARM

